

# Inspire

Multipurpose  
Intraoral Disease  
Detector

User manual

Eng

<b>1. Introduction</b>	<b>04</b>
- Features	
- Description	
- Overview	
<b>2. Safety Information</b>	<b>05</b>
- Warning and caution	
- Notes and references	
- Installation and connection	
- Operation	
- Maintenance	
<b>3. List of components</b>	<b>09</b>
<b>4. Parts and functions</b>	<b>10</b>
<b>5. Installation</b>	<b>11</b>
<b>6. How to use</b>	<b>12</b>
<b>7. Maintenance</b>	<b>14</b>
<b>8. Trouble shooting</b>	<b>15</b>
<b>9. Specification</b>	<b>16</b>
<b>10. Accessories</b>	<b>17</b>
<b>11. Warranty</b>	<b>17</b>
<b>12. Warranty card</b>	<b>18</b>

# 1 Introduction

Thank you for purchasing the device. The instructions described below have been designed to provide the necessary information for the successful operation, daily maintenance and safety for the use of this unit.

## Features

---

- Autofocus
- Software compatibility
- Mouse function

## Description

---

This device is an intraoral camera used to take images of the inside of the mouth or oral cavity.

## Overview

---

### 1) Camera

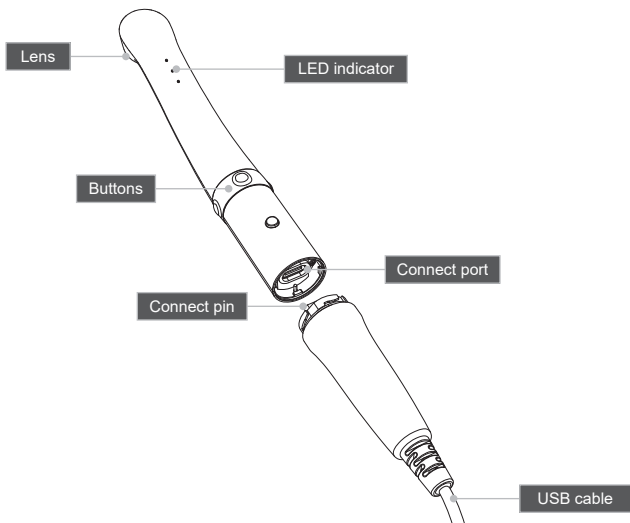

### 2) USB cable

## 2 Safety information

It is important to understand the following information to use this product safely.

### Warning and caution

---

Warning and caution used in this manual are shown below.



Indicates a potentially hazardous situation which, if not avoided, may result in serious injury or death.



Indicates a potentially hazardous situation which, if not avoided, may result in minor/moderate injury or in damage of property.

### Notes and references

---

Notes and references used in this manual are shown below.



Indicates that potential malfunctions may occur if the description is ignored.



Supplementary information to facilitate better operation.

## 2 Safety information

### Installation and connection

---



#### Warning

- Before use, check that there is no dust or foreign particles in the USB cable or connection part to avoid an electric shock.
- Keep away from sources of ignition.
- Protect the device from any liquid to avoid an electric shock or functional error.
- Place the device on a plate, stable surface, or cradle supplied.  
Dropping the device could result in an internal defect that may cause overheating or fire.
- Do not place the USB cable near a gas burner or other sources of heat. Should the cable catch on fire or become damaged, replace with a new one to avoid short-circuiting.



#### Caution

- Do not use or leave the unit in areas of high temperature or exposed to direct sunlight. Internal circuit faults may cause the device to overheat or catch on fire.
- Securely connect the dust-free USB cable. Use this device in well ventilated areas, as overheating may cause ignition.

## 2 Safety information

### Operation

---



#### Warning

- Do not plug in the USB cable with wet hands. This may result in an electric shock.
- Do not use this product on a person with a pacemaker as it may cause malfunction of the pacemaker.
- Use a disposable cover for each new patient to prevent cross-infection.



#### Caution

- Do not disconnect the USB cable by pulling on the cable. This may result in an electric shock or fire.
- Avoid damage or use of unnecessary force on the USB cable.  
This may result in an electric shock or fire.
- Remove the USB cable if the device is out of use for a long period of time.
- Do not use this product for any purpose other than dental use.
- This device is not waterproof. Use disposable covers to avoid wetting the device.  
In case of malfunction due to this case, it is not covered by warranty.
- The product may malfunction or the connection to the PC may be disconnected due to the ESD/EFT

## 2 Safety information

### Maintenance

---



#### Warning

- Never disassemble or repair the product, this may cause injuries, electric shock, or fire.
- Avoid getting the unit wet to prevent an electric shock.
- Ensure that the USB cable is disconnected prior to cleaning.



#### Caution

- Do not use solvents oil, ethanol, or acetone to clean or disinfect.
- The user must be in charge of the operation and maintenance of the device.

### 3 List of components

Please check the contents described below when removing the contents from the original packaging.

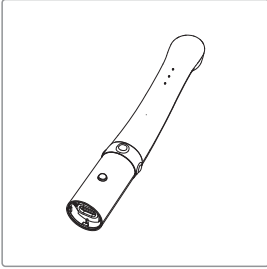

Camera

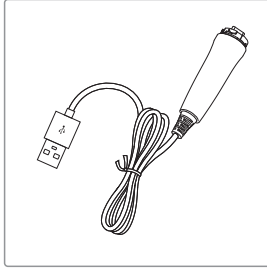

USB cable

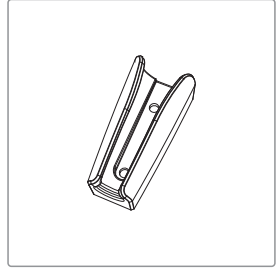

Cradle

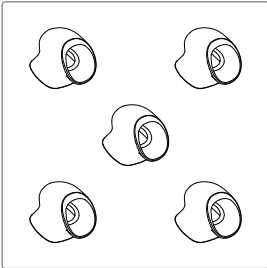

Silicon-cap

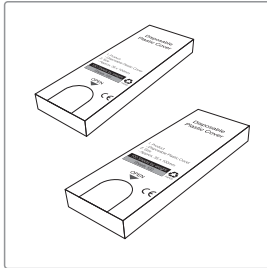

Disposable cover  
(x 100 pcs by weight)  
x 2ea



# 4 Parts and functions

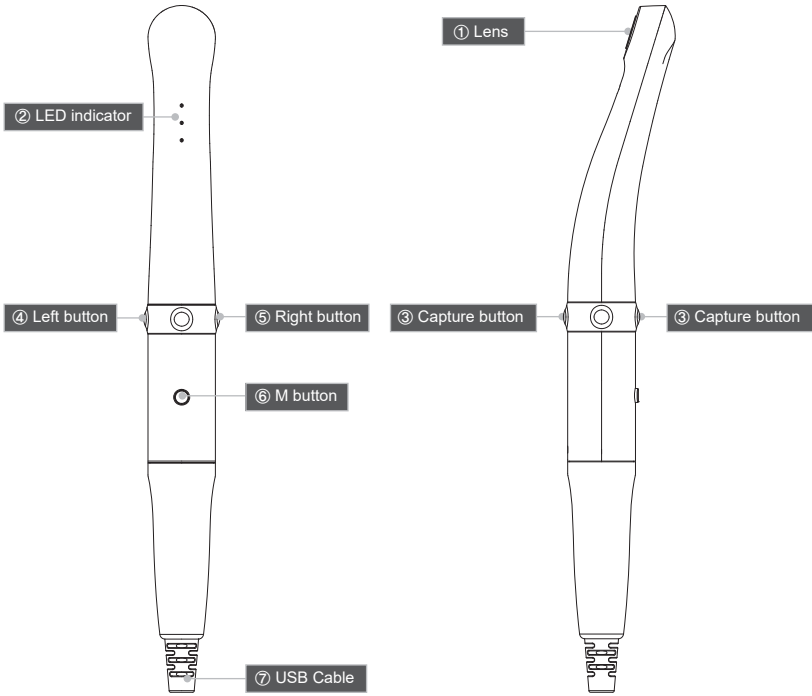

① Lens  
- Takes image and send to sensor

③ Capture button  
- Image capture, focus adjusting

② LED indicator  
- Show the device status

④ Left button  
- Mouse left button

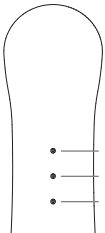

- ① LED indicator
- ② LED indicator
- ③ LED indicator

⑤ Right button  
- Mouse right button

⑥ M button  
- Mouse activation

⑦ USB Cable  
- Connect with camera and PC.

LED indicator	State	LED Color					
		●	●	●	●	OFF	
① LED	Camera mode	MI mode	TR mode	FL mode	3in1 mode	Black&White mode	
② LED	Color impression	MI mode	Original	Standard	Warm	-	-
		FL mode	F mode	S mode	-	-	-
③ LED	Auto-focus	Semi auto-focus	Full auto-focus	-	-	-	

# 5 Installation

## 1. USB cable connection

Connect the USB cable with body as follow picture.

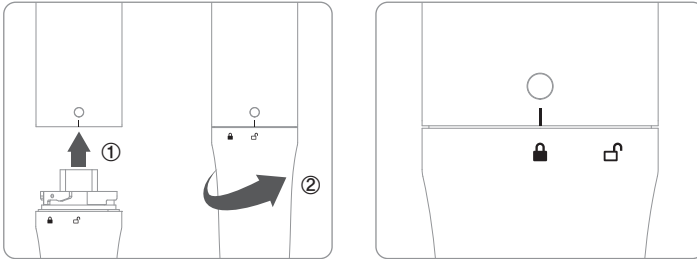

Be careful when connecting the USB cable to body. Do not force too much.

## 2. Use disposable cover

As shown in the picture below, put the disposable cover on the camera head to cover it.

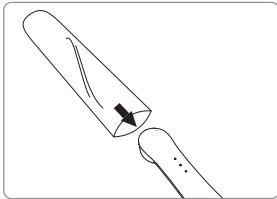

## 3. Use silicone cap (when using TR and FL mode)

Put the silicone cap on the camera head as shown below  
Be careful not to block the lens.

※ It is recommended to use the silicone cap as much as possible because it blocks the light from the outside and makes the shooting part clear, making the optimal condition for checking the caries condition.



## 4. Capture key setting

- Capture key can be changed with "HIDDrS Manager" in the USB.
- Default value is "Space"



Reference

If software capture key value is unknown, contact technical support.

# 6 How to use

## 1. Turn on the device

- Connect the device to PC. Then the device is turned on with LED blink with beep sound.

## 2. Image capture

2-1. Place the camera head equipped with a silicone cap on top of the teeth and capture

2-2. Semi auto-focus mode

- Half click: Adjust focus
- Full click: Image capture
- Half click & stay: Image capture after focus adjust.

2-3. Full auto-focus mode

- half click: Image capture

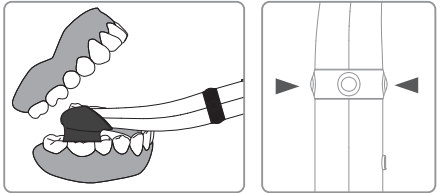

Reference

Default setup is semi auto-focus. And capture key is "Space"  
To use other company software, need to check capture key.  
Or need to use twain driver.

## 3. Mouse function

- Click M button and hold. Mouse cursor on the PC moves as device moves.
- Left / Right button works same as normal mouse button.

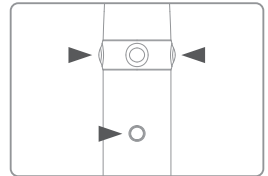

## 4. Black & White mode

- Click and hold M button with Right button for 1 sec.  
Then LED turn off, and live image changed to black & white mode with 1st LED indicator off.

- ●: Normal image
- OFF: Black & White image

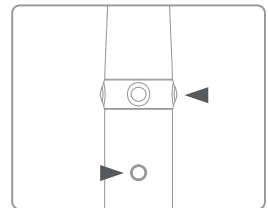

## 5. Zoom function

- Double click and hold M button. Then specific area is enlarged.

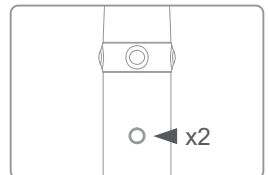

\* Need to install "Zoom function" program on the PC.

## 6 How to use

### 6. Camera mode

- Click and hold left and right button on live image.  
Then 1st LED indicator change as follow with camera mode changing.

- ●: MI mode
- ●: TR mode
- ●: FL mode
- Rotate(Blue-Red-Green): 3 in 1 mode  
3 images are captured at one time.  
(Normal, Transillumination, Fluorescence)

\* Normal -> TR -> FL -> 3 in 1 is rotated.

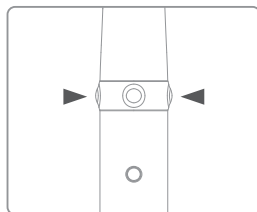

### 7. Color impression changing

- Click and hold mode button and capture button on live image.  
Then the color impression is changed 2nd LED indicator changed.

- \* MI mode
- ●: Original
- ●: Standard
- ●: Warm
- \* Original => Standard => Warm color impression is rotated.

- \* FL mode
- ●: F mode
- ●: S mode

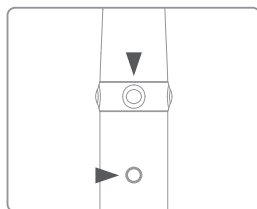

### 8. Focusing mode changing

- Click and hold up/bottom capture button on live image.  
Then the focusing mode is rotated Semi / Full auto-focus with  
3rd LED indicator change.

- ●: Semi auto-focus
- ●: Full auto-focus

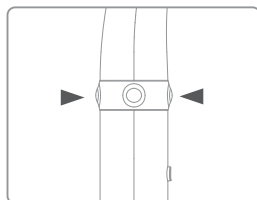

LED indicator	State		LED Color				
			●	●	●	●	OFF
① LED	Camera mode		MI mode	TR mode	FL mode	3in1 mode	Black&White mode
② LED	Color impression	MI mode	Original	Standard	Warm	-	-
		FL mode	F mode	S mode	-	-	-
③ LED	Auto-focus		Semi auto-focus	Full auto-focus	-	-	-

## 7 Maintenance

### Cleaning, Disinfecting and Sterilization Method for Components

- Clean the camera gently with clean, soft, lint-free cloth.
- Avoid using solvents which contain ethanol or acetone.
- Do not use sharp or pointed tools to clean as they may damage or scratch the plastic.
- Be careful not to spill any liquid into the device.
- Use disposable covers when using the device to avoid cross-infection and spilling any liquid into the device.

#### 1. Silicon cap

Clean and sterilize the silicon cap between each use.

#### 2. Cleaning Method

- 1) Rinse the soiled cap under running cold tap water for at least 2 minutes.  
Remove gross soil using a soft-bristle brush or clean, soft, lint-free cloth.
- 2) Immerse the cap and soak for a minimum of five (5) minutes in enzymatic detergent solution. Please refer to the enzymatic cleaner or the detergent manufacturer's instructions for preparation and use.
- 3) Use a soft-bristled brush to gently scrub the device until all visible soil is removed.
- 4) Remove the cap from the detergent solution and rinse in tap water for at least 3 minutes.
- 5) Perform final rinse using freshly prepared distilled water for at least 2 minutes.
- 6) Check the cap for visible soil. Repeat cleaning if soil is visible

#### Sterilization Method(Steam (Gravity))

Item	Exposure Time at 121°C (250°F)	Minimum Drying Times
Wrapped Instruments	30 minutes	30 minutes



Caution

Wraps used for sterilization should use the following products approved by FDA 510 (k). K143637  
Ref No. : UUPP0002 (STERILIZATION Pouch-Heat-Seal and Self-Seal)  
Size : 4"X10.25"

## Maintenance

- Do not disassemble the device for any purpose.
- To repair the device, please contact authorized dealer or manufacturer.
- Remove the USB cable from PC, if the device is not in use for long period.

## 8 Trouble shooting

If the device doesn't work normally, please refer to the following points.

Problem	Cause and solution
Button doesn't work	<p>If the button is pressed with excessive force, it would not work, try pressing the button gently.</p> <p>In case of installation or device setting is incorrect, the button could not work. Check the 5. Installation and 6. How to use.</p>
LED indicator does not work	<p>If the USB connection is not good, or USB electric power is not enough the camera will not work. Check the USB connection and use other USB port.</p>
Power off while in operation	<p>If the USB cable is not connected properly, the device may turn off. Check the USB cable connection.</p>
Not able to capture image	<p>Capture key-value will not match with other company dental imaging software. Please check keyboard shortcut. If you don't know please ask the dental imaging software vendor and check the key-value of device.</p>
Live image is not shown	<p>If the device is not recognized well, live image is not shown. Please check camera connection or imaging device of device manager.</p> <p>If there is TV tuner in the PC. The image could be not shown. Check "Disable" the TV tuner device on the device manager.</p> <p>If you use other company dental viewer software, it would be related with its setting. Please ask to the dental viewer software vendor.</p> <p>If you use other company dental viewer software, other imaging device (ex. Web-cam, etc.) should be checked for "Disable".</p> <p>Some codec makes block the live image shown. Uninstall the codec file. (ex. klite codec and etc.)</p>

\* If the trouble is not fixed after following solution, please contact your local dealer or manufacturer.

# 9 Specification

## ■ Equipment Class

Model:	IC-WHCD100
Trademark:	Inspire
Power supply:	5V USB power
Protection from ingress of liquids:	IPX0 (ordinary equipment)
Protection from electric shock:	Type B ⚡

## ■ Operation, transport, and storage condition for the main unit

	Operation	Storage	Transport
Temperature	10~30℃	10~40℃	-10C~50℃
Humidity	10~80%	20~80%	20~80%
Atmospheric pressure	800 ~ 1360 hPa		

## ■ Additional Information

Camera	Operation voltage	5V 600mA
	Measurement	Approx. 128 x 21.5 x 32 mm
	Weight	Approx. 61g
	Resolution	FHD (1920 x 1080)
	Sensor type	CMOS
USB cable	Length	Approx. 3 M
Disposable cover	Quantity	Approx. 100 pcs by weight x 2ea
	Raw material	Polyethylene

## ■ Minimum system requirement

PC system:	3.3GHz CPU, 4GB RAM
OS:	Windows 7
USB port:	USB 2.0

\* Upper specification is changeable without prior notice.

## ■ Information concerning the electromagnetic compatibility according to EN IEC 60601-1-2

Guidance and manufacture's declaration – electromagnetic emission		
The intraoral cameras is intended for use in the electromagnetic environment specified below. The customer of the user of the intraoral cameras should assure that it is used in such an environment.		
Emission test	Compliance	Electromagnetic environment – guidance
RF emissions CISPR 11	Group 1	The intraoral camera use RF energy only for its internal function. Therefore, its RF emissions are very low and are not likely to cause any interference in nearby electronic equipment
RF emission CISPR 11	Class A	The intraoral camera is suitable for use in all establishments, including domestic establishments and those establishments directly connected to the public low-voltage power supply network with specific
Harmonic emissions IEC 61000-3-2	Not applicable	
Voltage fluctuations/flicker emissions IEC 61000-3-3	Not applicable	

# 9 Specification

## Guidance and manufacture's declaration – electromagnetic immunity

The intraoral camera is intended for use in the electromagnetic environment specified below. The customer or the user of intraoral camera should assure that it is used in such an environment.

Immunity test	IEC 60601 test level	Compliance level	Electromagnetic environment - guidance
Electrostatic discharge (ESD) IEC 61000-4-2	±8 kV contact ±2 kV, ±4 kV, ±8 kV, ±15 kV	±8 kV contact ±2 kV, ±4 kV, ±8 kV, ±15 kV air	Floors should be wood, concrete or ceramic tile. If floor are covered with synthetic material, the relative humidity should be at least 30%.
Electrical fast transient/burst IEC 61000-4-4	±2kV for power supply lines ±1 kV for Input/output lines	Not applicable	Mains power quality should be that of a typical commercial or hospital environment.
Surge IEC 61000-4-5	±0.5 kV & ±1 kV differential mode ±0.5 kV, ±1 kV & ± 2 kV common mode	Not applicable	Mains power quality should be that of a typical commercial or hospital environment.
Voltage dips, short interruptions and voltage variations on power supply input lines IEC 61000-4-11	100 % <i>UT</i> (100% dip in <i>UT</i> ) for 0.5 cycle 100 % <i>UT</i> (100% dip in <i>UT</i> )for 1 cycle 30 % <i>UT</i> (70% dip in <i>UT</i> ) for 25/30 cycles 100 % <i>UT</i> (100% dip in <i>UT</i> ) for 250/300 cycle	Not applicable	Mains power quality should be that of a typical commercial or hospital environment. If the user of the model intraoral camera requires continued operation during power mains interruptions, it is recommended that the model intraoral camera be powered from an uninterruptible power supply or a battery.
Power frequency (50/60 Hz) magnetic field IEC 61000-4-8	3 A/m	3 A/m	Power frequency magnetic fields should be at levels characteristic of a typical location in a typical commercial or hospital environment.

NOTE:UT is the a.c. mains voltage prior to application of the test level.

## Guidance and manufacture's declaration – electromagnetic immunity

The intraoral camera is intended for use in the electromagnetic environment specified below. The customer or the user of intraoral camera should assure that it is used in such an environment.

Immunity test	IEC 60601 test level	Compliance level	Electromagnetic environment - guidance
Conducted RF IEC 61000-4-6	3 Vrms 150 kHz to 80 MHz 6 Vrms in ISM band 3 V/m 80 MHz to 2.7 GHz	Not applicable	Portable and mobile RF communications equipment should be used no closer to any part of the intraoral camera, including cables, than the recommended separation distance calculated from the equation applicable to the frequency of the transmitter. Recommended separation distance $d=1.2 \times \sqrt{P}^{1/2}$ $d=1.2 \times \sqrt{P}^{1/2}$ 80 MHz to 800 MHz $d=1.2 \times \sqrt{P}^{1/2}$ 800 MHz to 2,5 GHz
Radiated RF IEC 61000-4-3	385MHz-5785MHz Test specifications for ENCLOSURE PORT IMMUNITY to RF wireless communication equipment(Refer to table 9 of IEC 60601-1-2:2014)	3 V/m 80 MHz to 2.7GHz 385MHz-5785 Mhz Test specifications for ENCLOSURE PORT IMMUNITY to RF wireless communication equipment (Refer to table 9 of IEC 60601-1-2:2014)	transmitter in watts (W) according to the transmitter manufacturer and <i>d</i> is the recommended separation distance in meters (m).Field strengths from fixed RF transmitters, determined by an electromagnetic site survey,should be less than the compliance level in each frequency range'. Interference may occur in the vicinity of equipment marked with the following symbol: 

NOTE 1 U<sub>p</sub>is the a.c. mains voltage prior to application of the test level.

NOTE 2 At 80 MHz and 800 MHz, the higher frequency range applies.

NOTE 3 These guidelines may not apply in all situations. Electromagnetic propagation is affected by absorption and reflection from structures, objects and people.



# 9 Specification

- a. Field strengths from fixed transmitters, such as base stations for radio (cellular/cordless) telephones and land mobile radios, amateur radio, AM and FM radio broadcast and TV broadcast cannot be predicted theoretically with accuracy. To assess the electromagnetic environment due to fixed RF transmitters, an electromagnetic site survey should be considered. If the measured field strength in the location in which the intraoral camera used exceeds the applicable RF compliance level above, the intraoral camera should be observed to verify normal operation. If abnormal performance is observed, additional measures may be necessary, such as
- b. Over the frequency range 150 kHz to 80 MHz, field strengths should be less than 3 V/m.

### Recommended separation distances between portable and mobile RF communications equipment and the intraoral cameras.

The intraoral camera is intended for use in an electromagnetic environment in which radiated RF disturbances are controlled. The customer or the user of the intraoral camera can help prevent electromagnetic interference by maintaining a minimum distance between portable and mobile RF communications equipment (transmitters) and the intraoral camera as recommended below, according to the maximum output power of the communications equipment.

Rated maximum output power of transmitter (W)	Separation distance according to frequency of transmitter		
	150 kHz to 80 Mhz $d=1.2 \times \sqrt{P}^{1/2}$	80 Mhz to 800 MHz $d=1.2 \times \sqrt{P}^{1/2}$	80 MHz to 800 Mhz $d=2.3 \times \sqrt{P}^{1/2}$
0.01	Not applicable	0.12	0.23
0.1	Not applicable	0.38	0.73
1	Not applicable	1.2	2.3
10	Not applicable	3.8	7.3
100	Not applicable	12	23

For transmitters rated at a maximum output power not listed above, the recommended separation distance  $d$  in metres (m) can be estimated using the equation applicable to the frequency of the transmitter, where  $P$  is the maximum output power rating of the transmitter in watts (W) according to the transmitter manufacturer.

- NOTE 1 At 80 MHz and 800 MHz, the separation distance for the higher frequency range applies.  
NOTE 2 These guidelines may not apply in all situations. Electromagnetic propagation is affected by absorption and reflection from structures, objects and people.

### ■ Symbol



This device conforms with the European Directive, 93 / 42 / EEC which includes the requirements for electromagnetic compatibility



This symbol is affixed to fulfill the requirements of EU Directive 2012/19/EU Article 11. This equipment cannot be disposed of as unsorted municipal waste within the European Union. Follow local regulations for disposal.

SN

Serial number 00 00 00 0000  
Model / Month / Year / Serial



Warning, Caution



Type B applied part



Manufacturer









Authorized representative in the European Community



Check user manual.

## 9 Specification

 Prevent by wet.	 PAPER This box is paper recyclable.
 Do not device on place where get direct sunshine.	 Fragile item
 -10°C 50°C Transport temperature.	 No hooks
 Reuse is not allowed	

## 10 Accessories

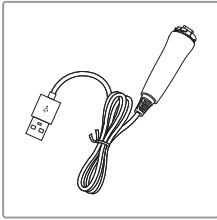

USB cable

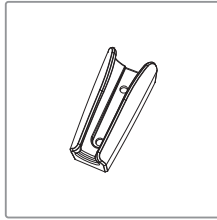

Cradle



Disposable cover  
(x 100 pcs by weight)

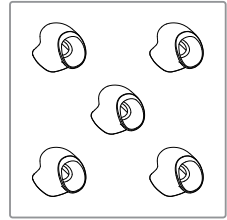

Silicon-cap

## 11 Warranty

This product is only shipped after strict inspection. Should the product incur any problems under normal use conditions within one year from the date of purchase, the repair will be free of charge. However, repair of consumables (Disposable Cover, and etc.) are not covered by the warranty. For more information, refer to the 12. Warranty card attached.

Serial number check.

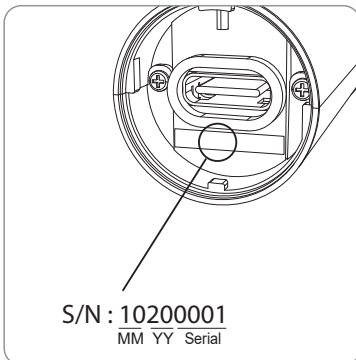

### EC REP Good Doctors Germany GmbH

Gerhard-Domagk-Str. 2, 53121 Bonn, Germany  
TEL: +49 (0) 228/53 44 14 65 FAX: +49 (0) 228/53 44 14 66  
www.gooddrs.de

### Good Doctors Co., Ltd.

#208, B-dong, 283 Bupyeong-daero, Bupyeong-gu  
(Woolim Lions Valley, Cheongchoen-dong), Incheon,  
21315, Republic of Korea  
Tel : + 82 32 424 6325 Fax : + 82 32 424 6326  
E-mail : info@gooddrs.com Website : www.gooddrs.com



We guarantee the quality of the product as follows

**Name of product :**

**Name of model :**

**Customer information**

- Office name :
- Office phone :

**Distributor**

- Dealer name :

**Assurance period**

- Date of purchase : from \_\_\_\_\_ , \_\_\_\_\_ , 20\_\_\_\_
- Product is for 1 year except accessories.

**< Assurance details >**

1. If there is any defect of manufacturer or product has any fault itself within the assurance period, it will be replaced with the same product.
2. Below cases are not effective for the free refund.
  - Malfunction and damage according to user's carelessness.
  - Malfunction and damage according to natural disaster such as fire, earthquake and flood etc.
  - Malfunction and damage according to user's intention or accident.
  - Malfunction and damage according to using incompatible product.
3. The manufacturer does not accept any liability resulting misuse.



**Good Doctors Co., Ltd.**

#208, B-dong, 283 Bupyeong-daero, Bupyeong-gu (Woolim Lions Valley, Cheongchoen-dong), Incheon, 21315, Republic of Korea

Tel: +82 32 424 6325 Fax: +82 32 424 6326

